

Side Deflector™ Ball Screw
AD/AH Series

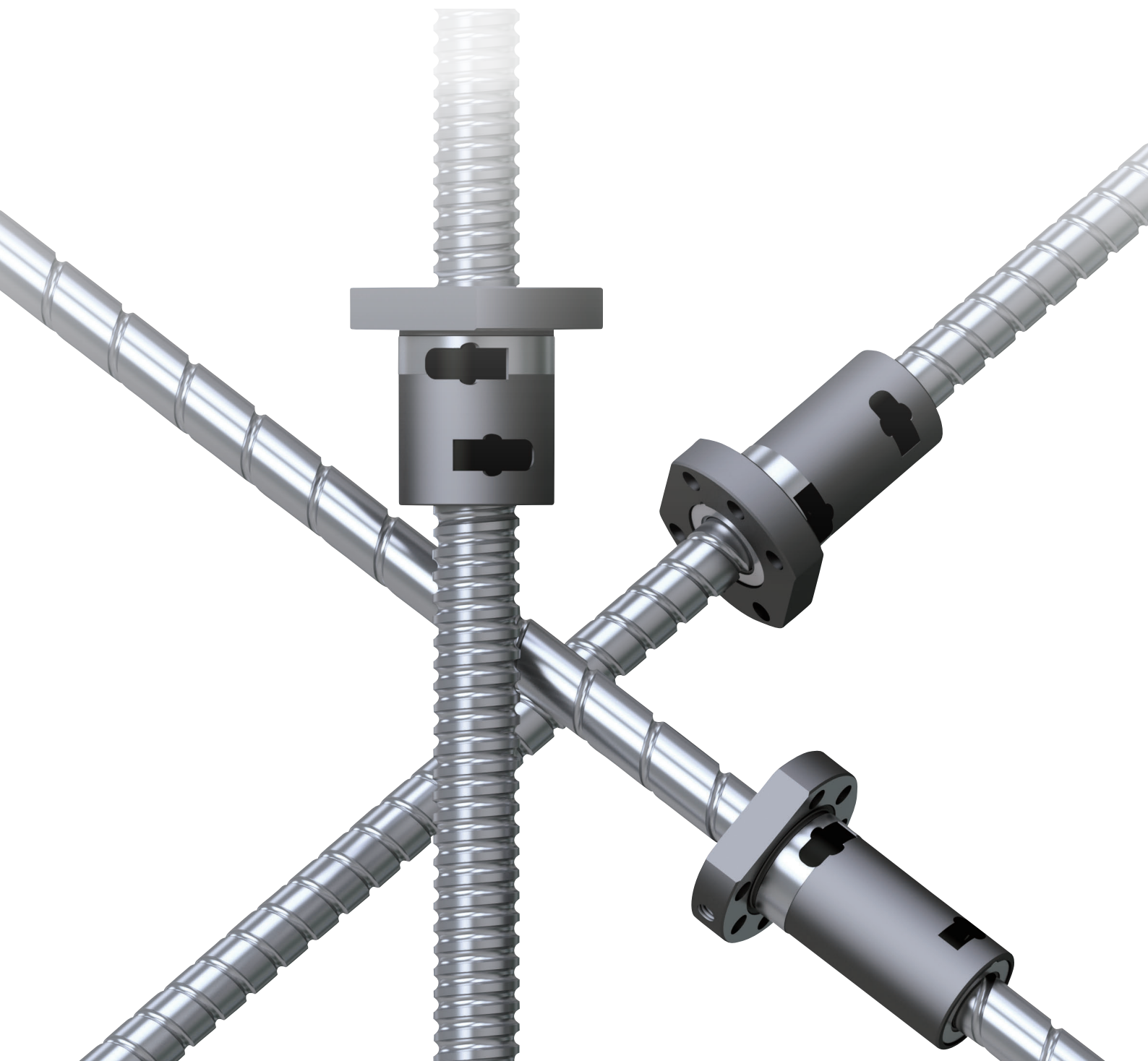

Smaller,
quieter,
faster.

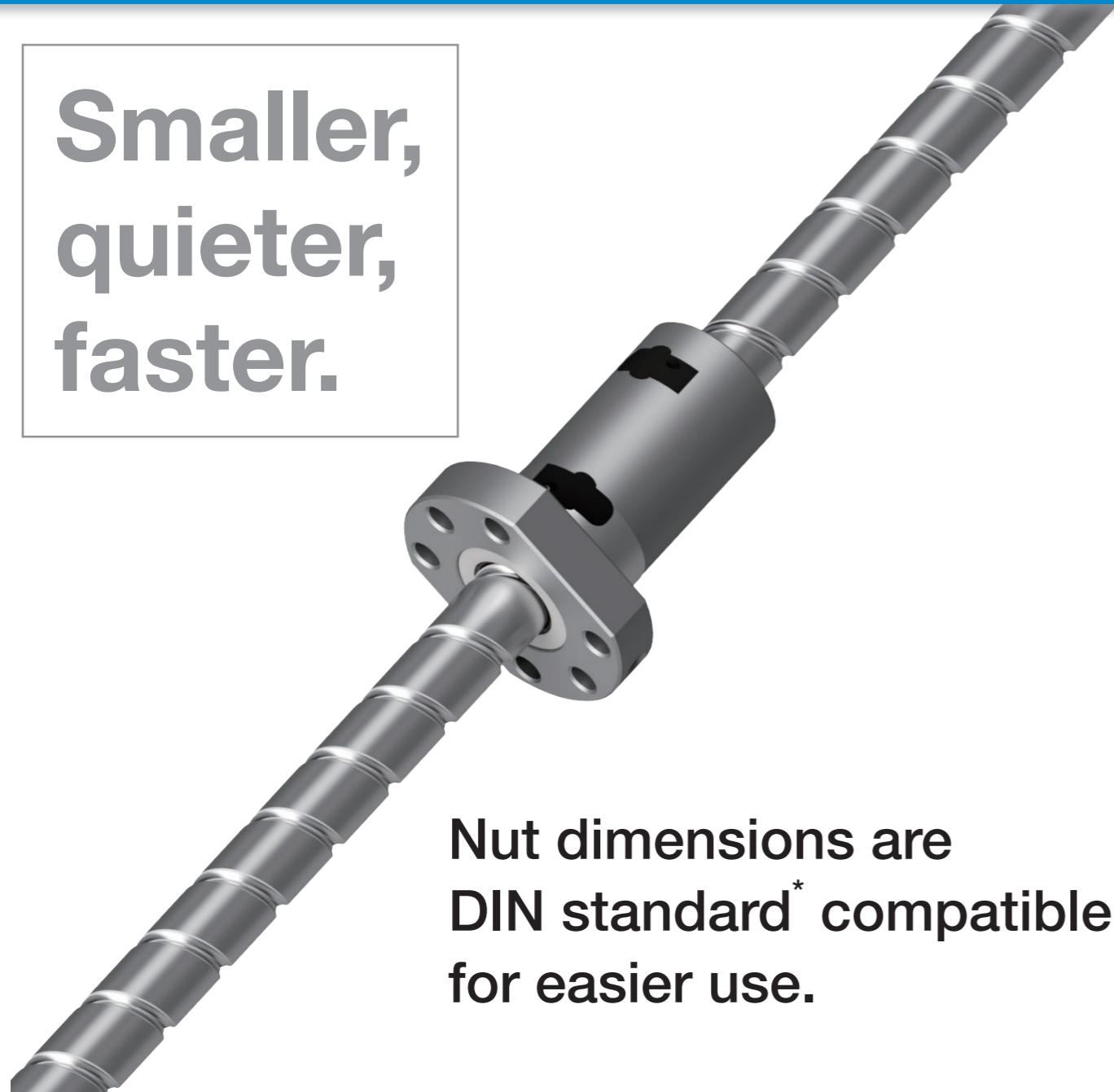

Nut dimensions are
DIN standard* compatible
for easier use.

New Circulation Method

A new circulation method (SIDE DEFLECTOR™) is used to achieve an optimal recirculation structure and an ideal transition for the ball into the recirculation passage. This design contributes to a more compact nut, higher speed, and quieter operation. The nut dimensions are DIN standard* compatible, for a nut that is both compact and easy to use.

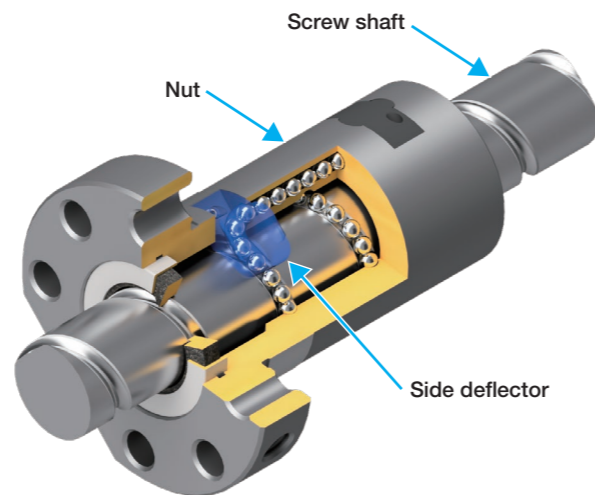

* Parts are shown colored above for improved visibility.

The SIDE DEFLECTOR™ method
delivers industry-leading performance.

High Speed

Designed to meet the needs of recent developments in automation as well as applications with strict takt time requirements, AD/AH Series Side Deflector Ball Screws offer greatly increased maximum rotational speeds and DN values. This high speed capability keeps in step with improvements in high performance motors. AD/AH Series ball screws deliver a maximum DN value of 150,000 (twice that of conventional products) and a maximum rotational speed of 5,000 min⁻¹.

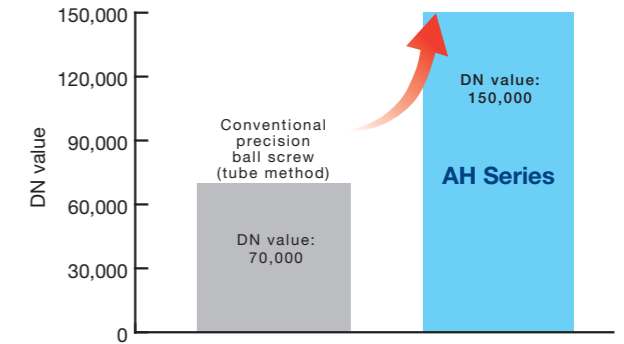

Quiet

Sound pressure has been reduced up to 6dB when compared to conventional tube recirculation method ball screws. Additionally, the AD/AH Series design greatly reduces high frequency sound, which provides a pleasing improvement in sonic performance.

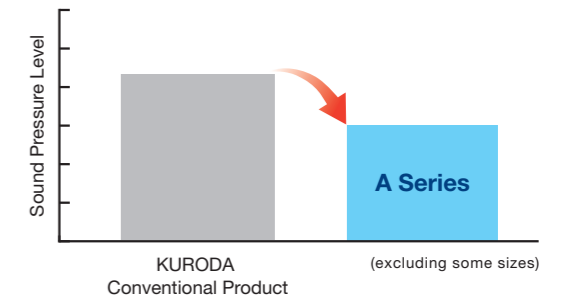

Compact

In an effort to support the space efficiency of our customers' equipment, Kuroda has developed a streamlined nut body with a compact flange, reducing nut size by 30% and nut weight by up to 50% when compared to conventional options.

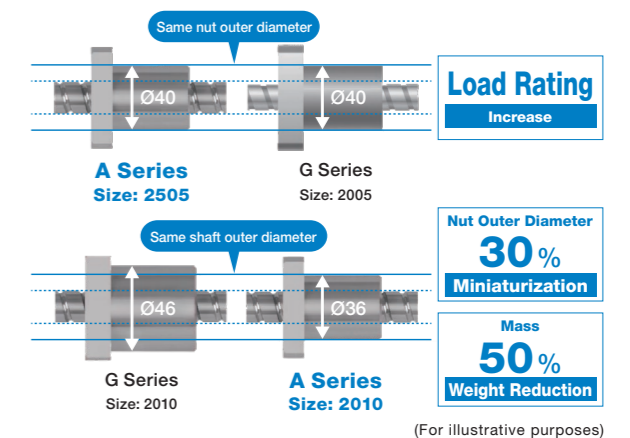

* DIN standards are a set of industrial standards created by the German Institute for Standardization (Deutsches Institut für Normung e.V.), that are widely used in various industrial fields across Europe, Asia and elsewhere. The nut dimensions for this product are compatible with DIN69051.

* SIDE DEFLECTOR is a registered trademark of KURODA.

* SIDE DEFLECTOR is a registered trademark of KURODA.

* The allowable rotational speed is the DN value, maximum rotational speed, or dangerous speed, whichever is lowest. Be sure to use the product at this allowable rotational speed or lower.

Equipped as standard with LUBSEAL™ lubrication unit for long-term maintenance-free operation.

Lubrication Unit Features

The “LUBSEAL” is a lubrication unit that is fitted in contact with the shaft thread and supplies a proper amount of lubricant. Built into the nut, LUBSEAL supplies the lubricating oil contained therein to the thread groove, entering the load region as the nut moves.

This contact type lubrication unit prevents contaminants from entering or excessive lubricant from flowing out, resulting in a lubrication unit that takes both contact area and contact pressure into consideration while also providing low sliding resistance.

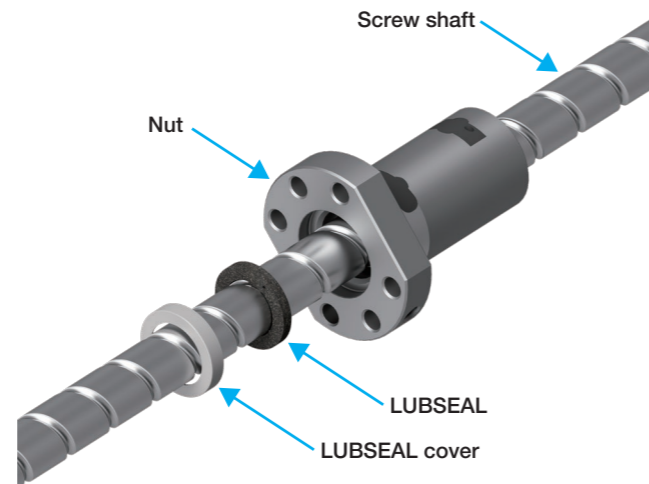

Space Saving

Designed to maximize ball screw performance without sacrificing shaft length, “LUBSEAL™” lubrication units prolong the period of maintenance-free operation with no loss in range of motion.

It is designed to have no effect on the mounting space or stroke, avoiding the need to redesign equipment to maximize ball screw performance.

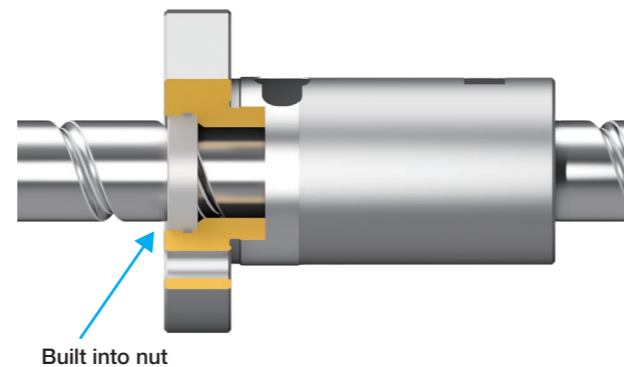

Structure and Performance

LUBSEAL™ makes contact with the raceway of the screw shaft thread groove. The lubricant contained in the nut is supplied to the raceway of the screw shaft through LUBSEAL™, ensuring that lubricant is supplied continuously and in just the right amount.

It also reduces the outflow of lubricating oil from the nut compared with other wipers or seals, reducing the amount of lubricant used even over long-term travel, and maintaining lubrication performance.

When tested under in-house experiment conditions, products achieved a travel durability of 50,000 km over.

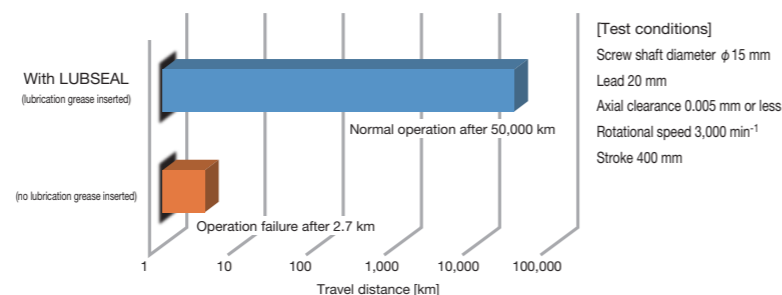
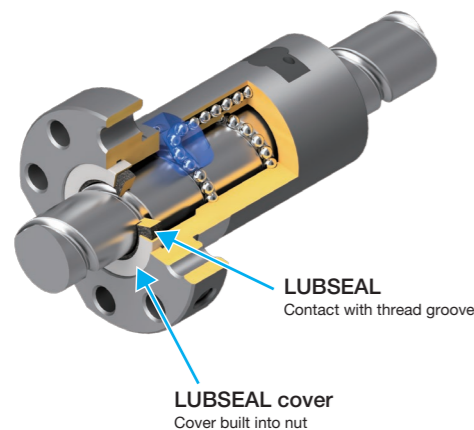

Side Deflector™ Ball Screw AD/AH Series

AD Series Page 7 on

Screw shaft nominal diameter ϕ 16

Lead 5 mm
10 mm
16 mm
20 mm

Screw shaft nominal diameter ϕ 20

Lead 5 mm
10 mm
20 mm

Screw shaft nominal diameter ϕ 25

Lead 5 mm
10 mm
25 mm

AH Series Page 15 on

Screw shaft nominal diameter ϕ 16

Lead 5 mm
10 mm
16 mm
20 mm

Screw shaft nominal diameter ϕ 20

Lead 5 mm
10 mm
20 mm

Screw shaft nominal diameter ϕ 25

Lead 5 mm
10 mm
25 mm

A Series Ball Screw

Application Examples

The AD/AH ball screws are ideal for a wide range of fields: semiconductor and LCD manufacturing equipment, transport robots, medical equipment, and inspection equipment.



Ball Screw Specifications

Series lineup: AH Series, AD Series

Screw shaft nominal diameter: Available in three sizes ($\phi 16$, $\phi 20$, $\phi 25$)

Lead: 5 mm, 10 mm, 16 mm, 20 mm, 25 mm (varies by screw shaft nominal diameter)

* The allowable rotational speed is the lowest value of the maximum rotational speed, DN value, and dangerous speed.

Shaft end shape (fixed end): Recommended shape available

Shaft end shape (supported end): Recommended shape available

Series	AD Series		AH Series	
	Screw Shaft Nominal Diameter	Lead	Screw Shaft Nominal Diameter	Lead
Lineup	16	5	16	5
		10		10
		16		16
		20		20
	20	5	20	5
		10		10
		20		20
	25	5	25	5
		10		10
		16		16
		25		25
	Accuracy Grade	C7		C5
Axial Clearance	0.010 mm or less 0.005 mm or less		0.005 mm or less 0 mm (preloaded)	
Lubrication Unit	LUBSEAL™		LUBSEAL™	
Maximum Rotational Speed	5,000 min ⁻¹		5,000 min ⁻¹	
DN Value	100,000		150,000	

Lubrication Unit LUBSEAL (Included)

A Series ball screws come equipped with KURODA's acclaimed LUBSEAL lubrication units.

The "LUBSEAL" is a lubrication unit that is fitted in contact with the shaft thread and supplies a proper amount of lubricant.

Designed to maximize ball screw performance without sacrificing shaft length, "LUBSEAL" lubrication units prolong the period of maintenance-free operation with no loss in range of motion.

This standard feature of A Series ball screws prevents damage to the operation zone of the nut and allows for long-term maintenance-free use.

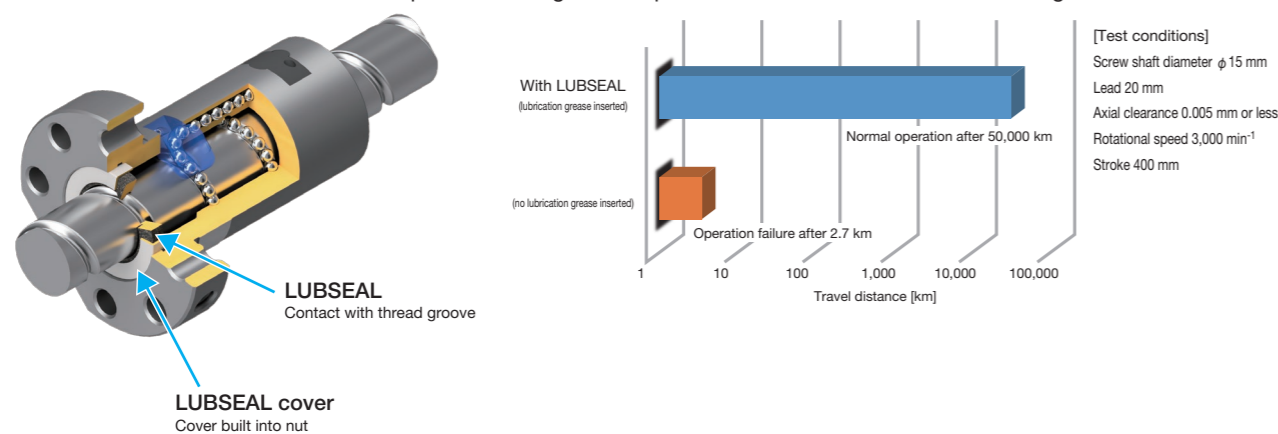

AD Series Ball Screws

Ball Screw Specifications

Screw shaft nominal diameter: $\phi 16$, $\phi 20$, $\phi 25$

Lead: 5 mm, 10 mm, 16 mm, 20 mm, 25 mm (available lead depends on screw shaft nominal diameter)

Accuracy grade: C7 Grade

Axial clearance: 0.010 mm or less / 0.005 mm or less

Lubrication unit: LUBSEAL™

Maximum rotational speed: 5,000 min⁻¹

DN value: 100,000

Model Number	Screw Shaft Nominal Diameter d [mm]	Lead L [mm]	Basic Dynamic Load Rating C [N]	Basic Static Load Rating C ₀ [N]	Accuracy Grade	Axial Clearance [mm]	Lubrication Unit /Wiper	Maximum Rotational Speed [min ⁻¹]
AD16054S-HSSR	16	5	7,600	12,000	C7	0.010 or less 0.005 or less	LUBSEAL™	5,000 (DN ≤ 100,000)
AD16103S-HSSR		10	5,700	8,700				
AD16162S-HSSR		16	3,800	5,500				
AD16202S-HSSR		20	3,700	5,500				
AD20054S-HSSR	20	5	10,400	18,500				
AD20103S-HSSR		10	7,800	13,400				
AD20202S-HSSR		20	5,100	8,500				
AD25054S-HSSR	25	5	11,400	23,100				
AD25103S-HSSR		10	8,700	16,900				
AD25252S-HSSR		25	5,700	10,600				

End Machining

Recommended shaft end configurations are available for each size of AD Series ball screws.

Additional machining for keyways, tap holes, D-cut machining and so on are also available upon request.

Optional Specifications

Surface treatment for AD Series ball screws is also available.

Anti-rust black oxide film treatment (film thickness 1-2 μm) is available upon request.

Please contact us for details.

Lubrication Unit

AD Series ball screws come equipped with LUBSEAL™ lubrication units.

Ball Screw Specifications

Nominal Model	AD16054S	AD16103S	AD16162S	AD16202S
Nominal Diameter [mm] - Lead [mm]	16 - 5	16 - 10	16 - 16	16 - 20
Number of Circuits / Thread Direction	3.7 turns per row / Right	2.7 turns per row / Right	1.7 turns per row / Right	1.7 turns per row / Right
Ball Diameter [mm]	2.778	2.778	2.778	2.778
Root Diameter [mm]	12.7	12.7	12.7	12.7
Basic Dynamic Load Rating C [N]	7,600	5,700	3,800	3,700
Basic Static Load Rating C ₀ [N]	12,000	8,700	5,500	5,500
Accuracy Grade	C7	C7	C7	C7
Clearance Symbol / Axial Clearance [mm]	H / 0.010 or less F / 0.005 or less	H / 0.010 or less F / 0.005 or less	H / 0.010 or less F / 0.005 or less	H / 0.010 or less F / 0.005 or less
Ball Re-Circulation System	Side Deflector™ method	Side Deflector™ method	Side Deflector™ method	Side Deflector™ method
Wiper / Lubrication Unit	LUBSEAL™	LUBSEAL™	LUBSEAL™	LUBSEAL™
Lubricant	Multemp LRL No.3	Multemp LRL No.3	Multemp LRL No.3	Multemp LRL No.3
Maximum Rotational Speed [min ⁻¹]	5,000 DN ≤ 100,000	5,000 DN ≤ 100,000	5,000 DN ≤ 100,000	5,000 DN ≤ 100,000

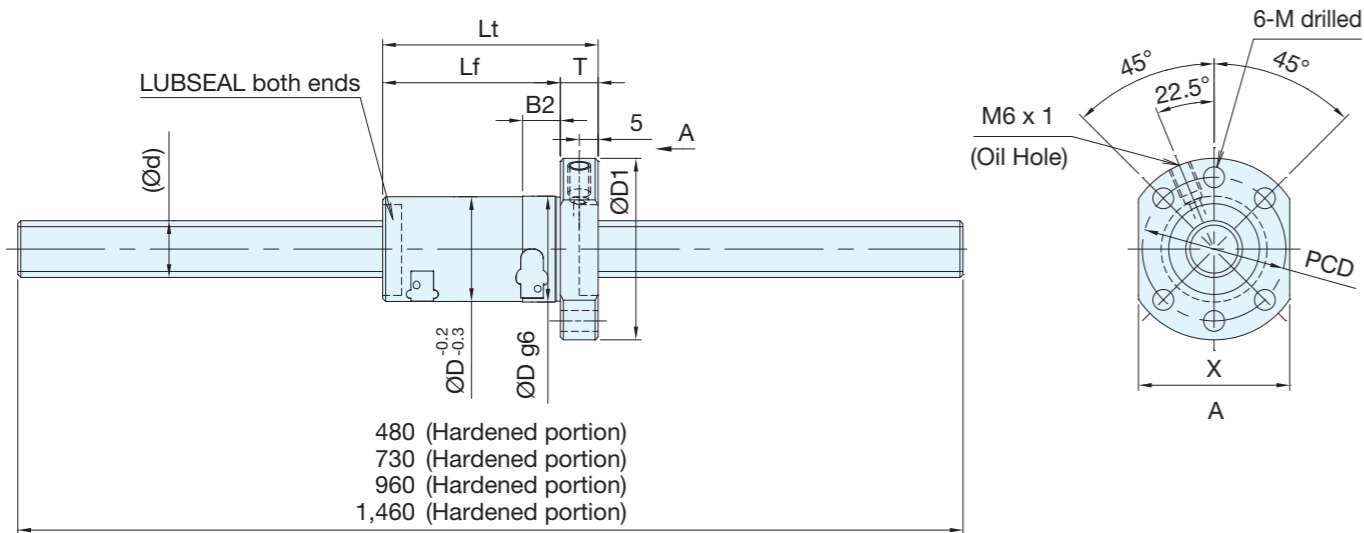

Nominal Model	Nominal Diameter	Lead Ph	Screw Shaft Diameter d	Nut Dimensions								
				Outer Diameter D	Flange Diameter D1	Total Length Lt	Thickness T	Body Length Lf	Length B2	Mounting Hole PCD	Mounting Hole Diameter M	Width X
AD16054S	16	5	15	28	48	47	10	37	10	38	5.5	40
AD16103S		10				57		47				
AD16162S		16				58		48				
AD16202S		20				66		56				

Guide to Model Numbers

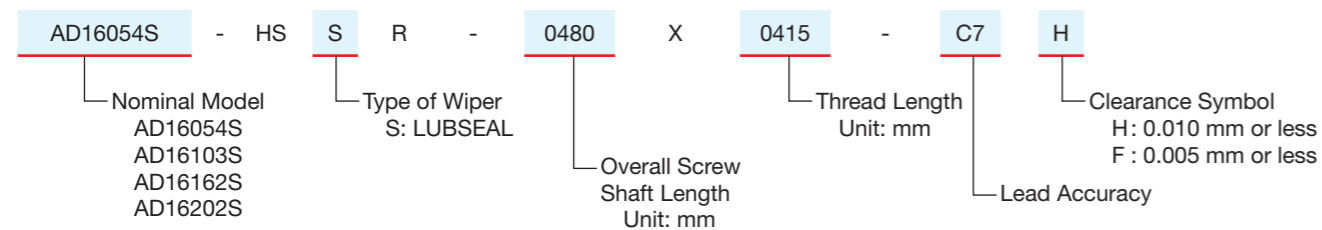

Shaft End Design

Recommended shaft end configurations are available by size for AD Series ball screws.

As well as our recommended shaft end configuration below, additional machining for keyways, tap holes, D-cut machining, etc. are also available upon request.

A sample machined shaft end configuration is shown below.

Model example: Shaft end not machined (left page) ⇒ Shaft end machined
AD16054S-HSSR-0480A ⇒ AD16054S-HSSR-0480 X 0415 -C7H

Thread Length
Overall Screw Shaft Length

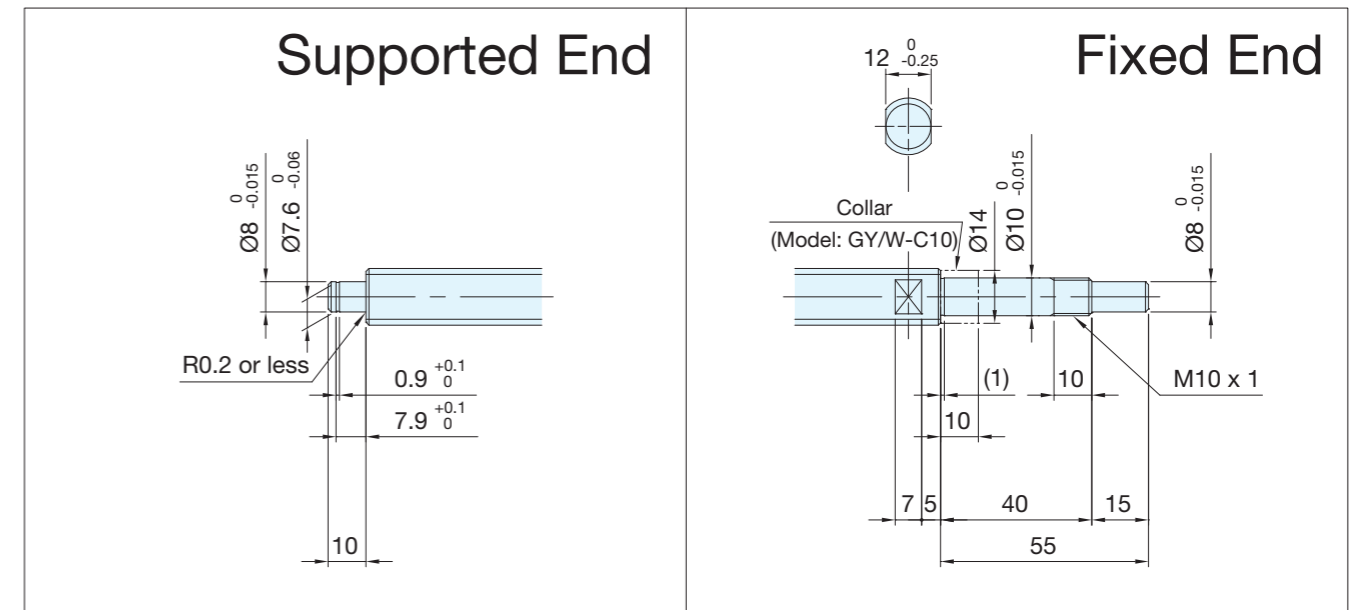

Applicable Support Units

Applicable supported end support units	Applicable fixed end support units
BUK-8S (square) Refer to page 22	BUK-10F (square) Refer to page 22
BUM-8S (round) Refer to page 23	BUM-10F (round) Refer to page 23

Optional Specifications

Anti-rust black oxide film treatment (film thickness 1-2 μm) is available.

Ball Screw Specifications

Nominal Model	AD20054S	AD20103S	AD20202S
Nominal Diameter [mm] - Lead [mm]	20 - 5	20 - 10	20 - 20
Number of Circuits / Thread Direction	3.7 turns per row / Right	2.7 turns per row / Right	1.7 turns per row / Right
Ball Diameter [mm]	3.175	3.175	3.175
Root Diameter [mm]	17.5	17.5	17.5
Basic Dynamic Load Rating C [N]	10,400	7,800	5,100
Basic Static Load Rating C_0 [N]	18,500	13,400	8,500
Accuracy Grade	C7	C7	C7
Clearance Symbol / Axial Clearance [mm]	H / 0.010 or less F / 0.005 or less	H / 0.010 or less F / 0.005 or less	H / 0.010 or less F / 0.005 or less
Ball Re-Circulation System	Side Deflector™ method	Side Deflector™ method	Side Deflector™ method
Wiper / Lubrication Unit	LUBSEAL™	LUBSEAL™	LUBSEAL™
Lubricant	Multemp LRL No.3	Multemp LRL No.3	Multemp LRL No.3
Maximum Rotational Speed [min^{-1}]	5,000 DN \leq 100,000	5,000 DN \leq 100,000	5,000 DN \leq 100,000

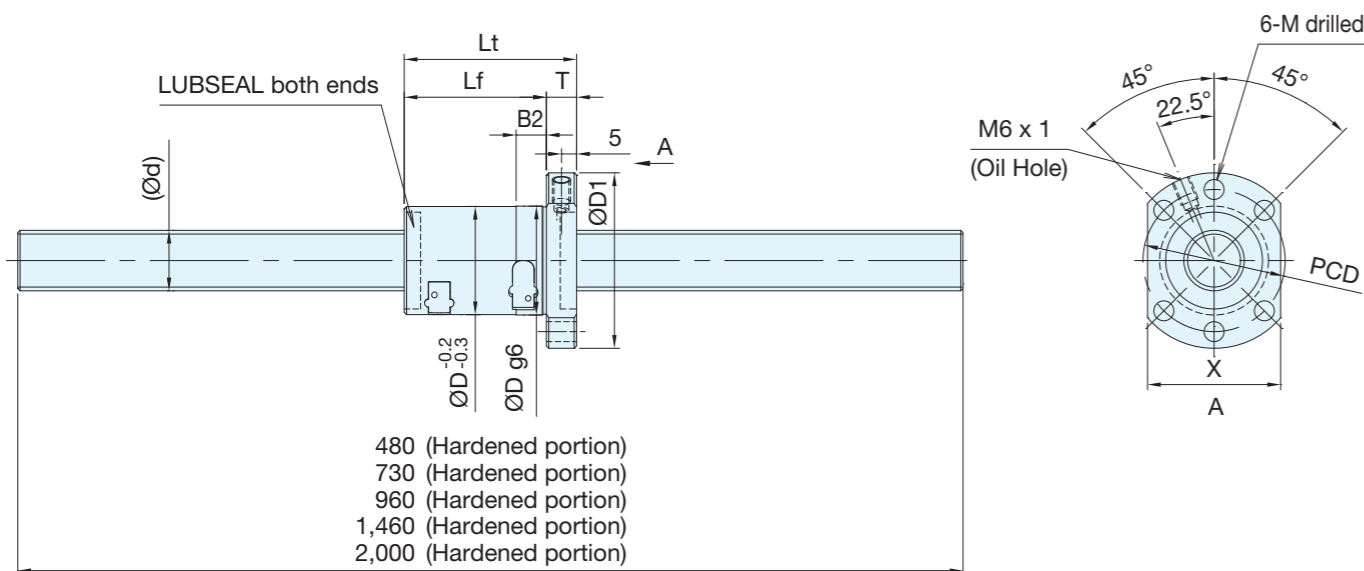

Nominal Model	Nominal Diameter	Lead Ph	Screw Shaft Diameter d	Nut Dimensions								
				Outer Diameter D	Flange Diameter D1	Total Length Lt	Thickness T	Body Length Lf	Length B2	Mounting Hole PCD	Mounting Hole Diameter M	Width X
AD20054S	20	5	20	36	58	50	10	40	10	47	6.6	44
AD20103S		10				57		47				
AD20202S		20				66		56				

Guide to Model Numbers

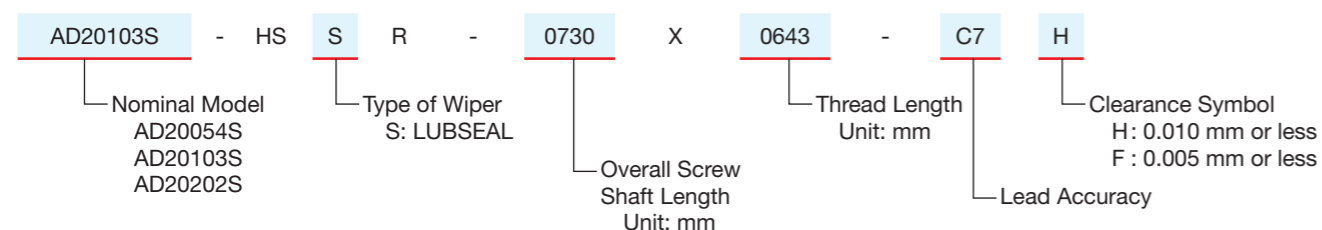

Shaft End Design

Recommended shaft end configurations are available by size for AD Series ball screws.

As well as our recommended shaft end configuration below, additional machining for keyways, tap holes, D-cut machining, etc. are also available upon request.

A sample machined shaft end configuration is shown below.

Model example: Shaft end not machined (left page) \Rightarrow Shaft end machined
 AD20103S-HSSR-0730A \Rightarrow AD20103S-HSSR-0730 X 0643 -C7H
 \rightarrow Thread Length
 \rightarrow Overall Screw Shaft Length

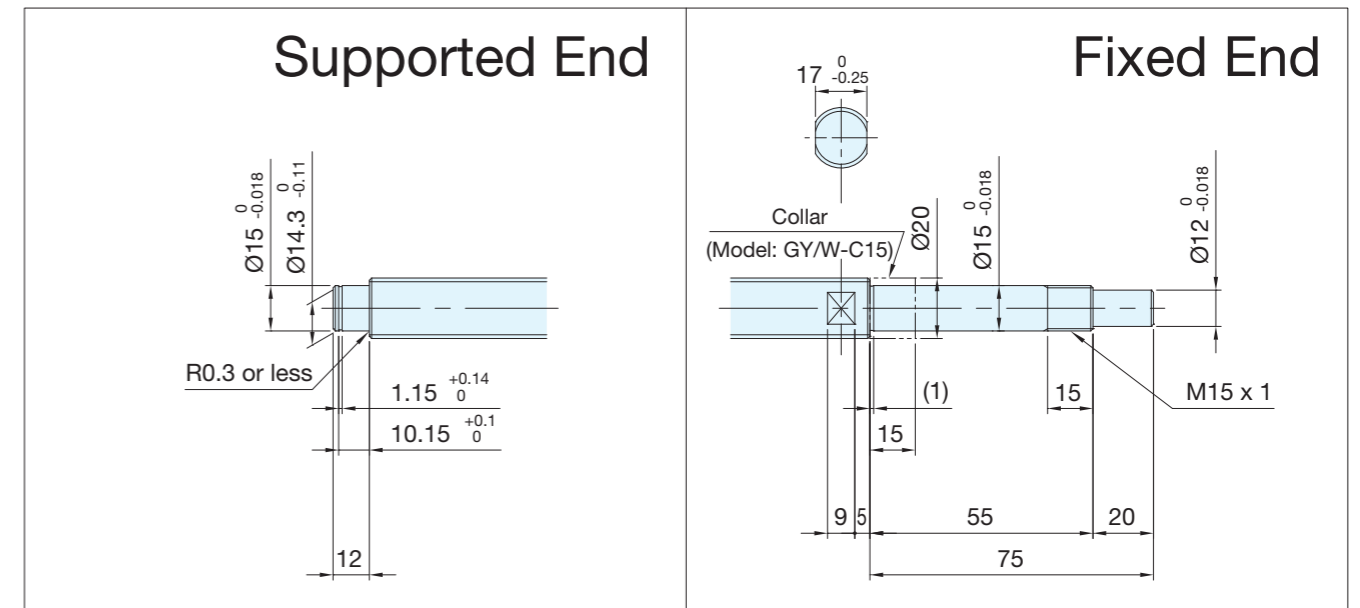

Applicable Support Units

Applicable supported end support units	Applicable fixed end support units
BUK-15S (square) Refer to page 22	BUK-15F (square) Refer to page 22
BUM-15S (round) Refer to page 23	BUM-15F (round) Refer to page 23

Optional Specifications

Anti-rust black oxide film treatment (film thickness 1-2 μm) is available.

Ball Screw Specifications

Nominal Model	AD25054S	AD25103S	AD25252S
Nominal Diameter [mm] - Lead [mm]	25 - 5	25 - 10	25 - 25
Number of Circuits / Thread Direction	3.7 turns per row / Right	2.7 turns per row / Right	1.7 turns per row / Right
Ball Diameter [mm]	3.175	3.175	3.175
Root Diameter [mm]	22.5	22.5	22.5
Basic Dynamic Load Rating C [N]	11,400	8,700	5,700
Basic Static Load Rating C ₀ [N]	23,100	16,900	10,600
Accuracy Grade	C7	C7	C7
Clearance Symbol / Axial Clearance [mm]	H / 0.010 or less F / 0.005 or less	H / 0.010 or less F / 0.005 or less	H / 0.010 or less F / 0.005 or less
Ball Re-Circulation System	Side Deflector™ method	Side Deflector™ method	Side Deflector™ method
Wiper / Lubrication Unit	LUBSEAL™	LUBSEAL™	LUBSEAL™
Lubricant	Multemp LRL No.3	Multemp LRL No.3	Multemp LRL No.3
Maximum Rotational Speed [min ⁻¹]	5,000 DN ≤ 100,000	5,000 DN ≤ 100,000	5,000 DN ≤ 100,000

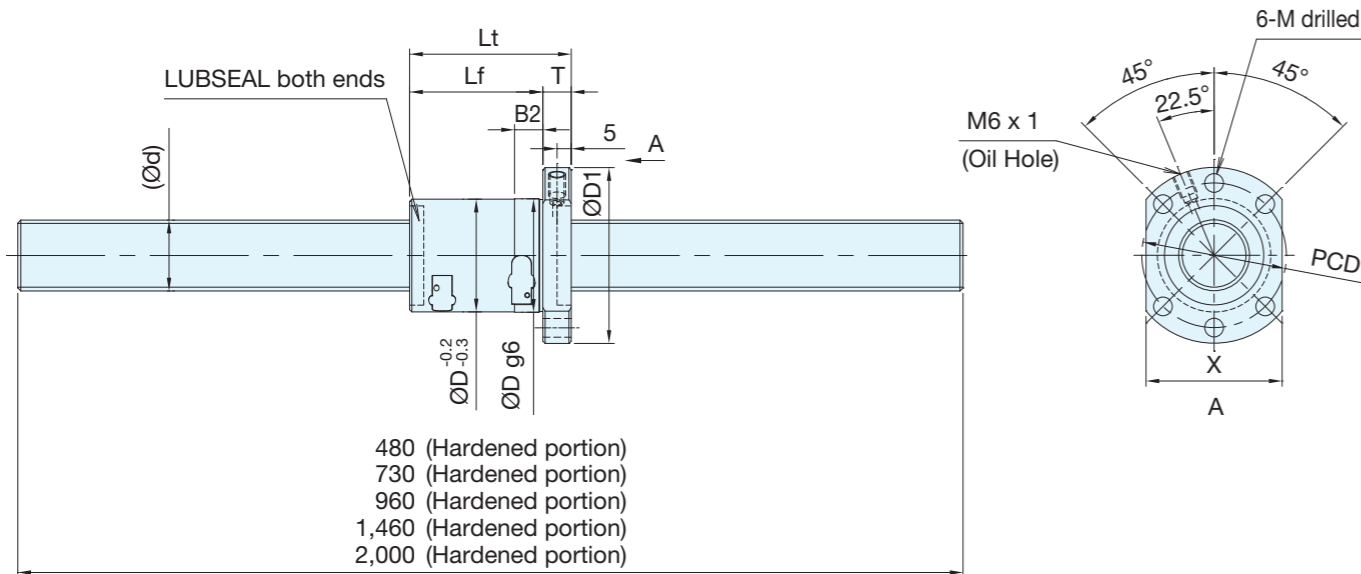

Nominal Model	Nominal Diameter	Lead Ph	Screw Shaft Diameter d	Nut Dimensions								
				Outer Diameter D	Flange Diameter D1	Total Length Lt	Thickness T	Body Length Lf	Length B2	Mounting Hole PCD	Mounting Hole Diameter M	Width X
AD25054S	25	5	25	40	62	47	10	37	10	51	6.6	48
AD25103S		10				57		47				
AD25252S		25				76		66				

Guide to Model Numbers

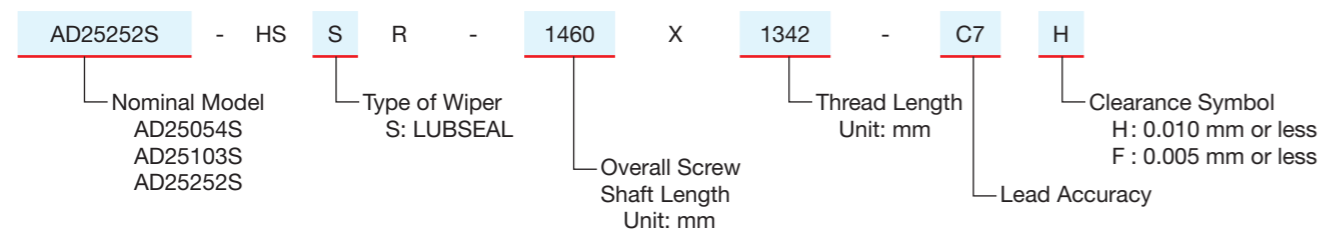

Shaft End Design

Recommended shaft end configurations are available by size for AD Series ball screws.

As well as our recommended shaft end configuration below, additional machining for keyways, tap holes, D-cut machining, etc. are also available upon request.

A sample machined shaft end configuration is shown below.

Model example: Shaft end not machined (left page) ⇒ Shaft end machined
AD25252S-HSSR-1460A ⇒ AD25252S-HSSR-1460 X 1342 -C7H

→ Thread Length
→ Overall Screw Shaft Length

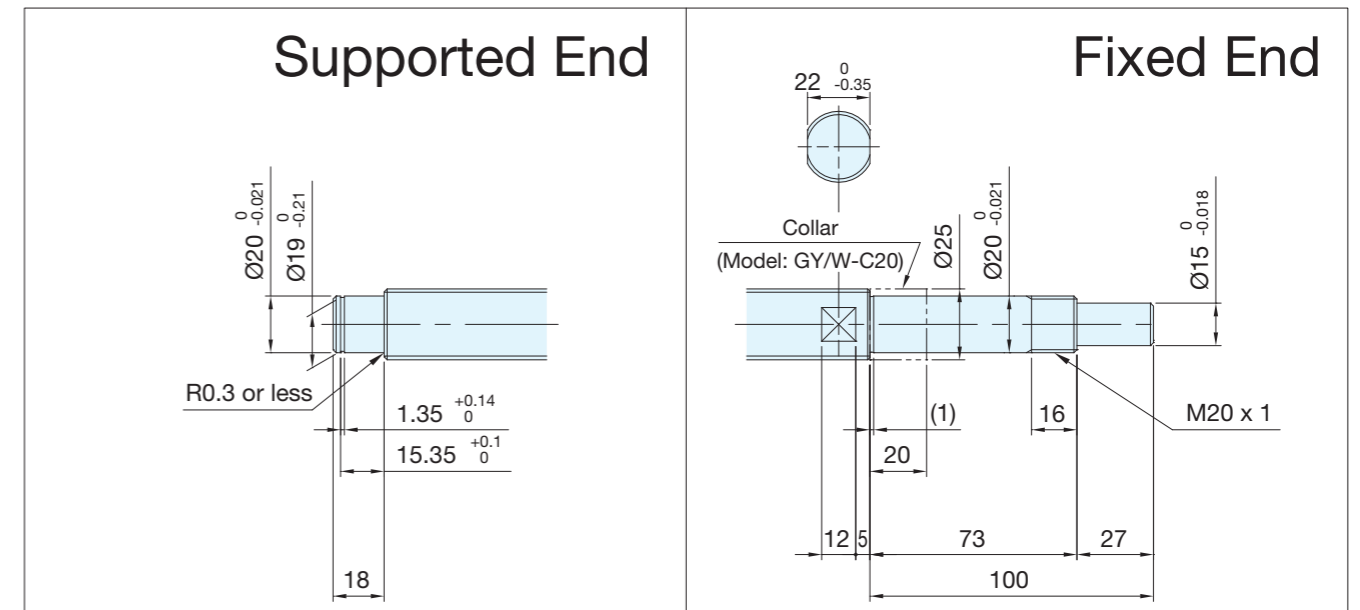

Applicable Support Units

Applicable supported end support units	Applicable fixed end support units
BUK-20S (square) Refer to page 22	BUK-20F (square) Refer to page 22
BUM-20S (round) Refer to page 23	BUM-20F (round) Refer to page 23

Optional Specifications

Anti-rust black oxide film treatment (film thickness 1-2 μm) is available.

Ball Screw Specifications

Nominal Model	AH16054S	AH16103S	AH16162S	AH16202S
Nominal Diameter [mm] - Lead [mm]	16 - 5	16 - 10	16 - 16	16 - 20
Number of Circuits / Thread Direction	3.7 turns per row / Right	2.7 turns per row / Right	1.7 turns per row / Right	1.7 turns per row / Right
Ball Diameter [mm]	2.778	2.778	2.778	2.778
Root Diameter [mm]	12.7	12.7	12.7	12.7
Basic Dynamic Load Rating C [N]	8,400	6,300	4,200	4,100
Basic Static Load Rating C ₀ [N]	13,300	9,700	6,100	6,100
Accuracy Grade	C5	C5	C5	C5
Clearance Symbol / Axial Clearance [mm]	F / 0.005 or less S / 0 (Preloaded)	F / 0.005 or less S / 0 (Preloaded)	F / 0.005 or less S / 0 (Preloaded)	F / 0.005 or less S / 0 (Preloaded)
Preload Torque [N·cm]	0.1 to 8.5	0.1 to 8.6	0.1 to 7.4	0.1 to 7.8
Ball Re-Circulation System	Side Deflector™ method	Side Deflector™ method	Side Deflector™ method	Side Deflector™ method
Wiper / Lubrication Unit	LUBSEAL™	LUBSEAL™	LUBSEAL™	LUBSEAL™
Lubricant	Multemp LRL No.3	Multemp LRL No.3	Multemp LRL No.3	Multemp LRL No.3
Maximum Rotational Speed [min ⁻¹]	5,000 DN ≤ 150,000	5,000 DN ≤ 150,000	5,000 DN ≤ 150,000	5,000 DN ≤ 150,000

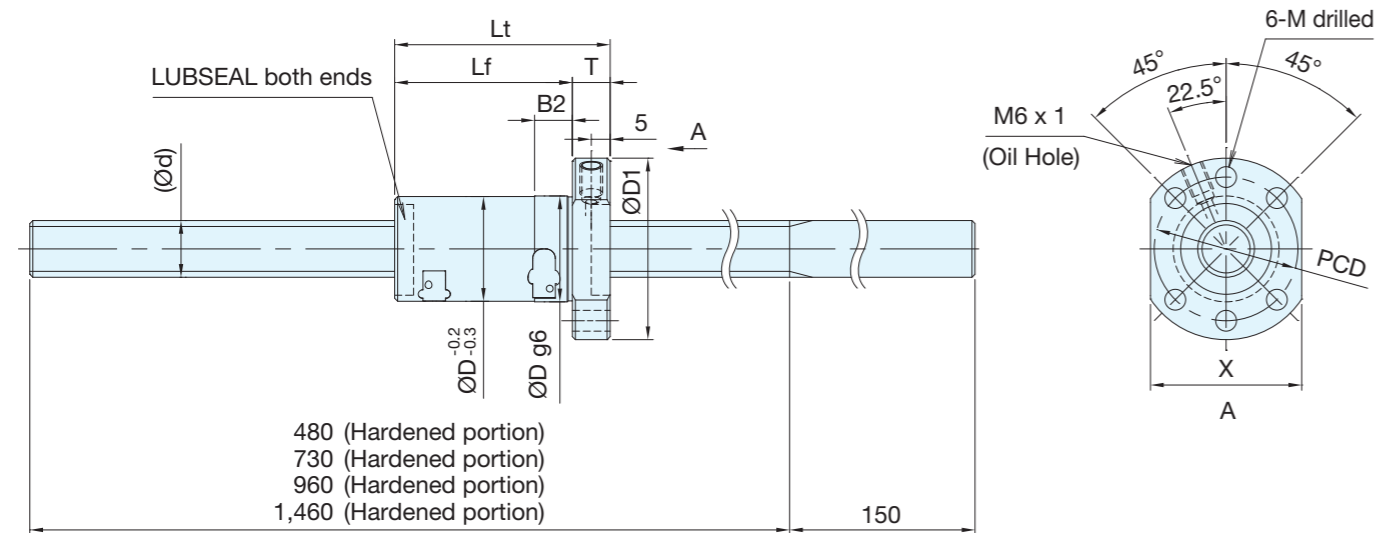

Nominal Model	Nominal Diameter	Lead Ph	Screw Shaft Diameter d	Nut Dimensions								
				Outer Diameter D	Flange Diameter D1	Total Length Lt	Thickness T	Body Length Lf	Length B2	Mounting Hole PCD	Mounting Hole Diameter M	Width X
AH16054S	16	5	15	28	48	47	10	37	10	38	5.5	40
AH16103S		57				47						
AH16162S		58				48						
AH16202S		66				56						

Guide to Model Numbers

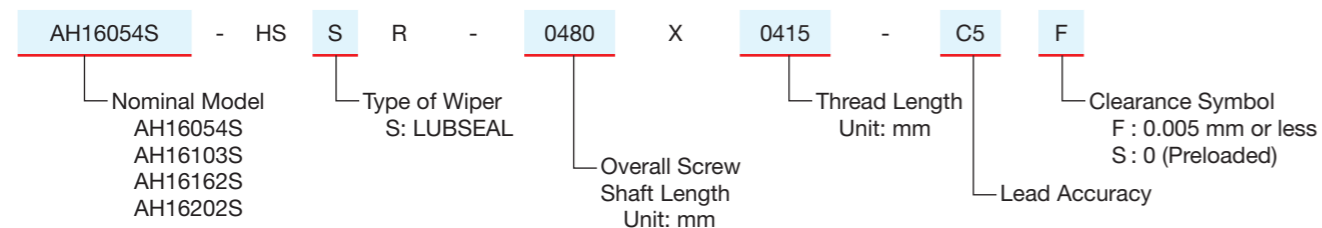

Shaft End Design

Recommended shaft end configurations are available by size for AH Series ball screws.

As well as our recommended shaft end configuration below, additional machining for keyways, tap holes, D-cut machining, etc. are also available upon request.

A sample machined shaft end configuration is shown below.

Model example: Shaft end not machined (left page) → Shaft end machined
 AH16054S-HSSR-0480A → AH16054S-HSSR-0480 X 0415 -C5F

→ Thread Length
 → Overall Screw Shaft Length

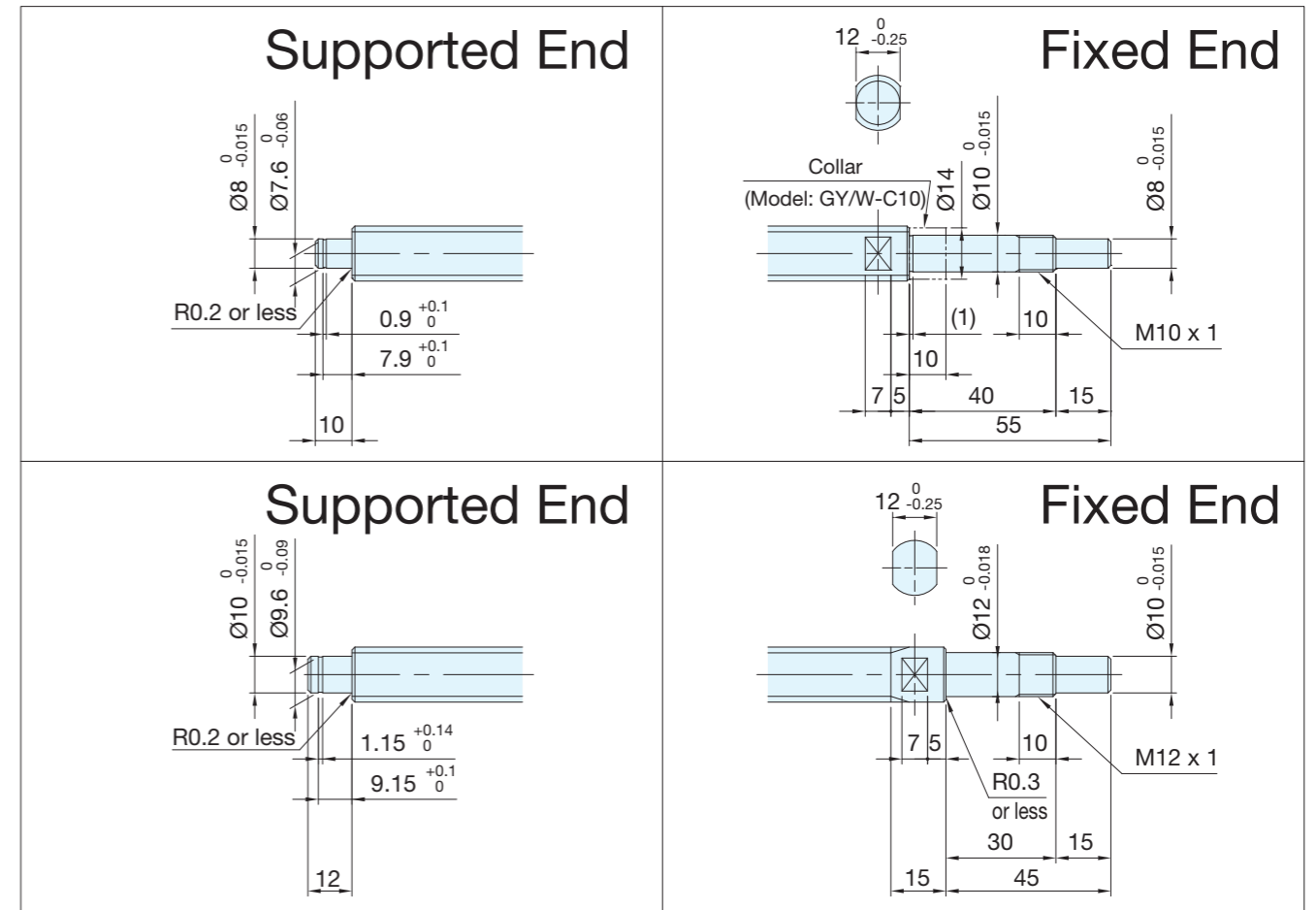

Applicable Support Units

Applicable supported end support units	Applicable fixed end support units
BUK-8S (square) Refer to page 22 BUK-10S (square) Refer to page 22	BUK-10F (square) Refer to page 22 BUK-12F (square) Refer to page 22
BUM-8S (round) Refer to page 23 BUM-10S (round) Refer to page 23	BUM-10F (round) Refer to page 23 BUM-12F (round) Refer to page 23

Optional Specifications

Anti-rust black oxide film treatment (film thickness 1-2 μm) is available.

Ball Screw Specifications

Nominal Model	AH20054S	AH20103S	AH20202S
Nominal Diameter [mm] - Lead [mm]	20 - 5	20 - 10	20 - 20
Number of Circuits / Thread Direction	3.7 turns per row / Right	2.7 turns per row / Right	1.7 turns per row / Right
Ball Diameter [mm]	3.175	3.175	3.175
Root Diameter [mm]	17.5	17.5	17.5
Basic Dynamic Load Rating C [N]	11,500	8,700	5,700
Basic Static Load Rating C ₀ [N]	20,500	14,900	9,400
Accuracy Grade	C5	C5	C5
Clearance Symbol / Axial Clearance [mm]	F / 0.005 or less S / 0 (Preloaded)	F / 0.005 or less S / 0 (Preloaded)	F / 0.005 or less S / 0 (Preloaded)
Preload Torque [N-cm]	0.2 to 13.0	0.3 to 13.7	0.3 to 12.8
Ball Re-Circulation System	Side Deflector™ method	Side Deflector™ method	Side Deflector™ method
Wiper / Lubrication Unit	LUBSEAL™	LUBSEAL™	LUBSEAL™
Lubricant	Multemp LRL No.3	Multemp LRL No.3	Multemp LRL No.3
Maximum Rotational Speed [min ⁻¹]	5,000 DN ≤ 150,000	5,000 DN ≤ 150,000	5,000 DN ≤ 150,000

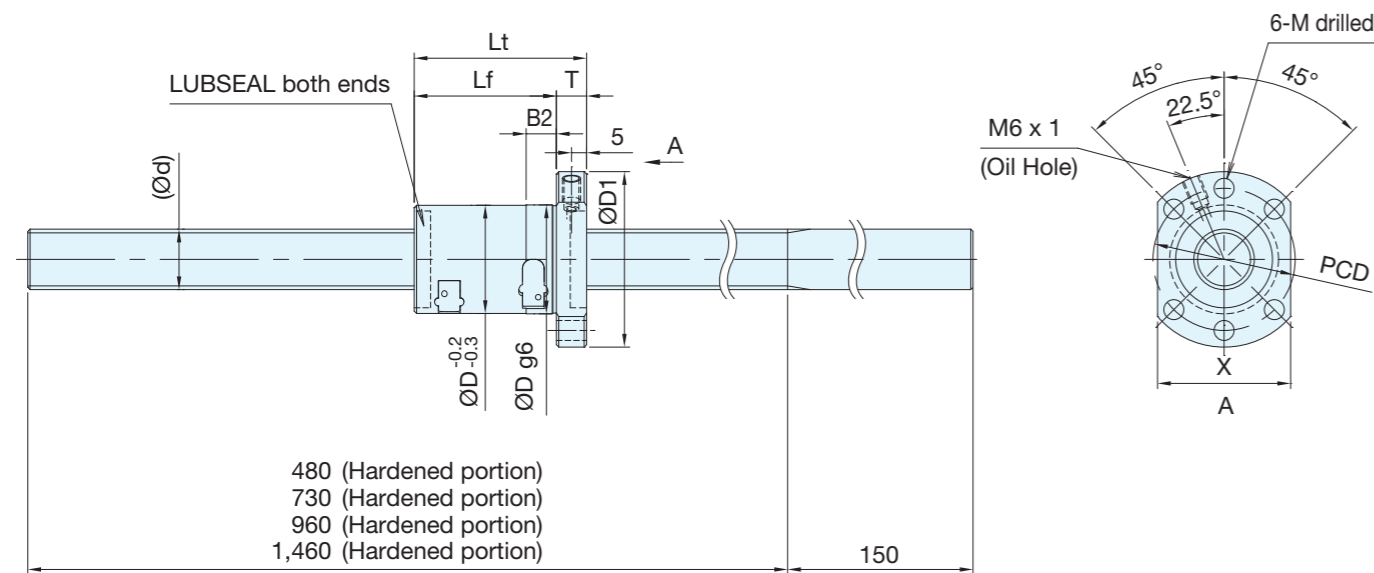

Nominal Model	Nominal diameter	Lead Ph	Screw Shaft Diameter d	Nut Dimensions								
				Outer Diameter D	Flange Diameter D1	Total Length Lt	Thickness T	Body Length Lf	Length B2	Mounting Hole PCD	Mounting Hole Diameter M	Width X
AH20054S	20	5	20	36	58	50	10	40	10	47	6.6	44
AH20103S		10				57		47				
AH20202S		20				66		56				

Guide to Model Numbers

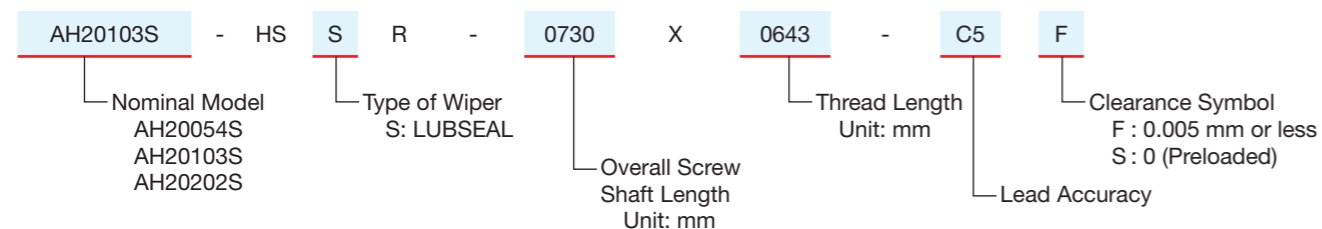

Shaft End Design

Recommended shaft end configurations are available by size for AH Series ball screws.

As well as our recommended shaft end configuration below, additional machining for keyways, tap holes, D-cut machining, etc. are also available upon request. A sample machined shaft end configuration is shown below.

Model example: Shaft end not machined (left page) → Shaft end machined
AH20103S-HSSR-0730A → AH20103S-HSSR-0730 X 0643 -C5F

→ Thread Length
→ Overall Screw Shaft Length

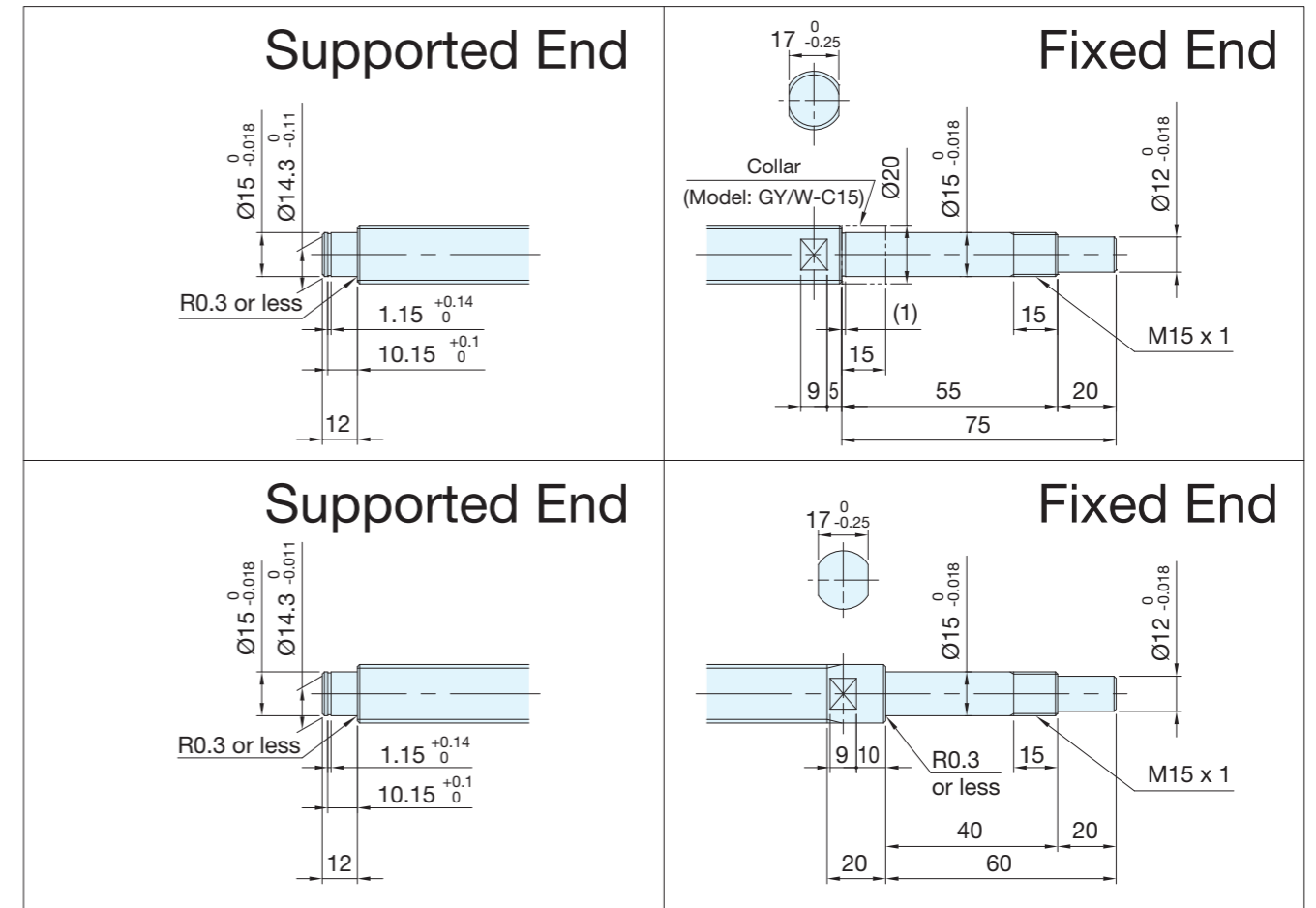

Applicable Support Units

Applicable supported end support units	Applicable fixed end support units
BUK-15S (square) Refer to page 22	BUK-15F (square) Refer to page 22
BUM-15S (round) Refer to page 23	BUM-15F (round) Refer to page 23

Optional Specifications

Anti-rust black oxide film treatment (film thickness 1-2 μm) is available.

Ball Screw Specifications

Nominal Model	AH25054S	AH25103S	AH25252S
Nominal Diameter [mm] - Lead [mm]	25 - 5	25 - 10	25 - 25
Number of Circuits / Thread Direction	3.7 turns per row / Right	2.7 turns per row / Right	1.7 turns per row / Right
Ball Diameter [mm]	3.175	3.175	3.175
Root Diameter [mm]	22.5	22.5	22.5
Basic Dynamic Load Rating C [N]	12,700	9,700	6,300
Basic Static Load Rating C ₀ [N]	25,700	18,800	11,800
Accuracy Grade	C5	C5	C5
Clearance Symbol / Axial Clearance [mm]	F / 0.005 or less S / 0 (Preloaded)	F / 0.005 or less S / 0 (Preloaded)	F / 0.005 or less S / 0 (Preloaded)
Preload Torque [N-cm]	0.1 to 16.3	0.2 to 17.8	0.2 to 18.2
Ball Re-Circulation System	Side Deflector™ method	Side Deflector™ method	Side Deflector™ method
Wiper / Lubrication Unit	LUBSEAL™	LUBSEAL™	LUBSEAL™
Lubricant	Multemp LRL No.3	Multemp LRL No.3	Multemp LRL No.3
Maximum Rotational Speed [min ⁻¹]	5,000 DN ≤ 150,000	5,000 DN ≤ 150,000	5,000 DN ≤ 150,000

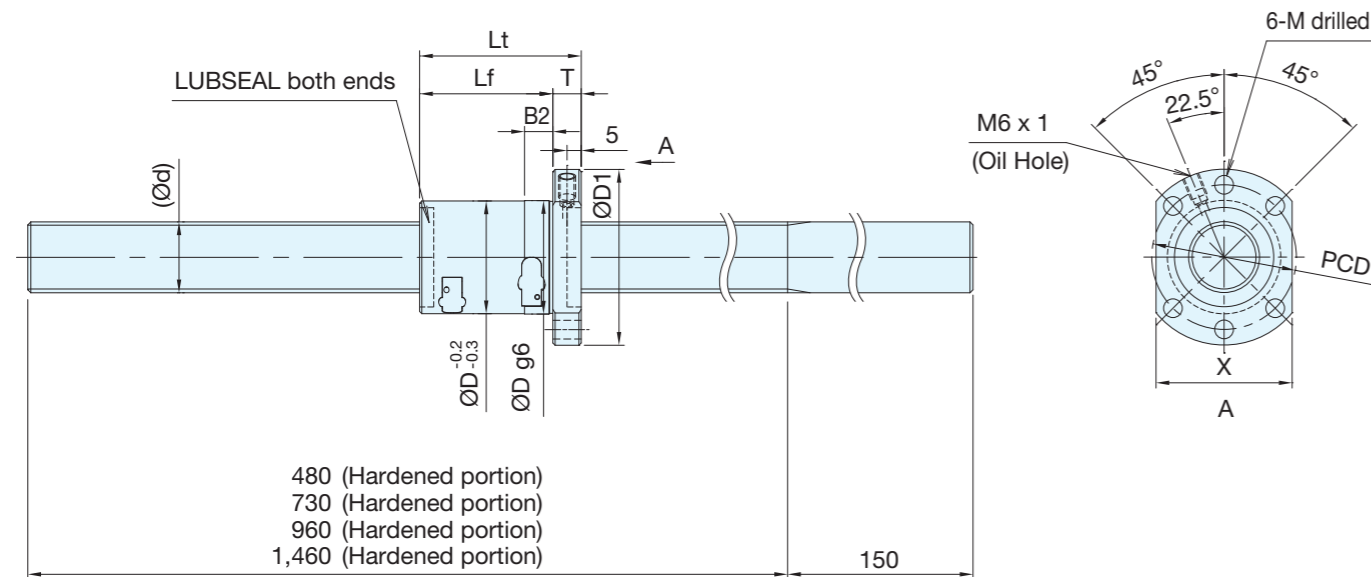

Nominal Model	Nominal Diameter	Lead Ph	Screw Shaft Diameter d	Nut Dimensions								
				Outer Diameter D	Flange Diameter D1	Total Length Lt	Thickness T	Body Length Lf	Length B2	Mounting Hole PCD	Mounting Hole Diameter M	Width X
AH25054S	25	5	25	40	62	47	10	37	10	51	6.6	48
AH25103S		57				47						
AH25252S		76				66						

Guide to Model Numbers

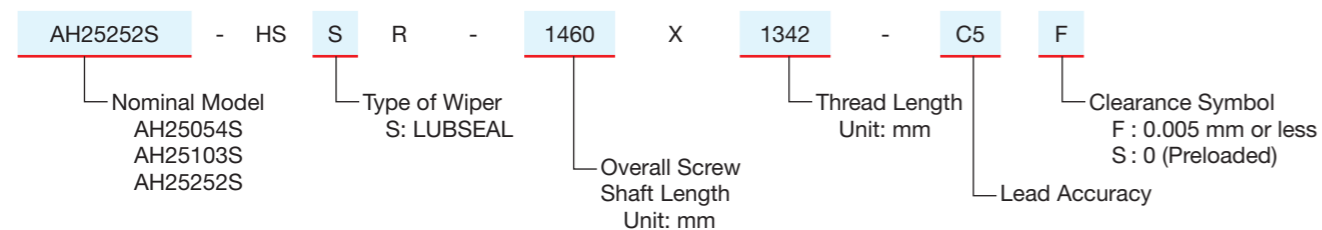

Shaft End Design

Recommended shaft end configurations are available by size for AH Series ball screws.

As well as our recommended shaft end configuration below, additional machining for keyways, tap holes, D-cut machining, etc. are also available upon request. A sample machined shaft end configuration is shown below.

Model example: Shaft end not machined (left page) → Shaft end machined
AH25252S-HSSR-1460A → AH25252S-HSSR-1460 X 1342 -C5F

Thread Length
Overall Screw Shaft Length

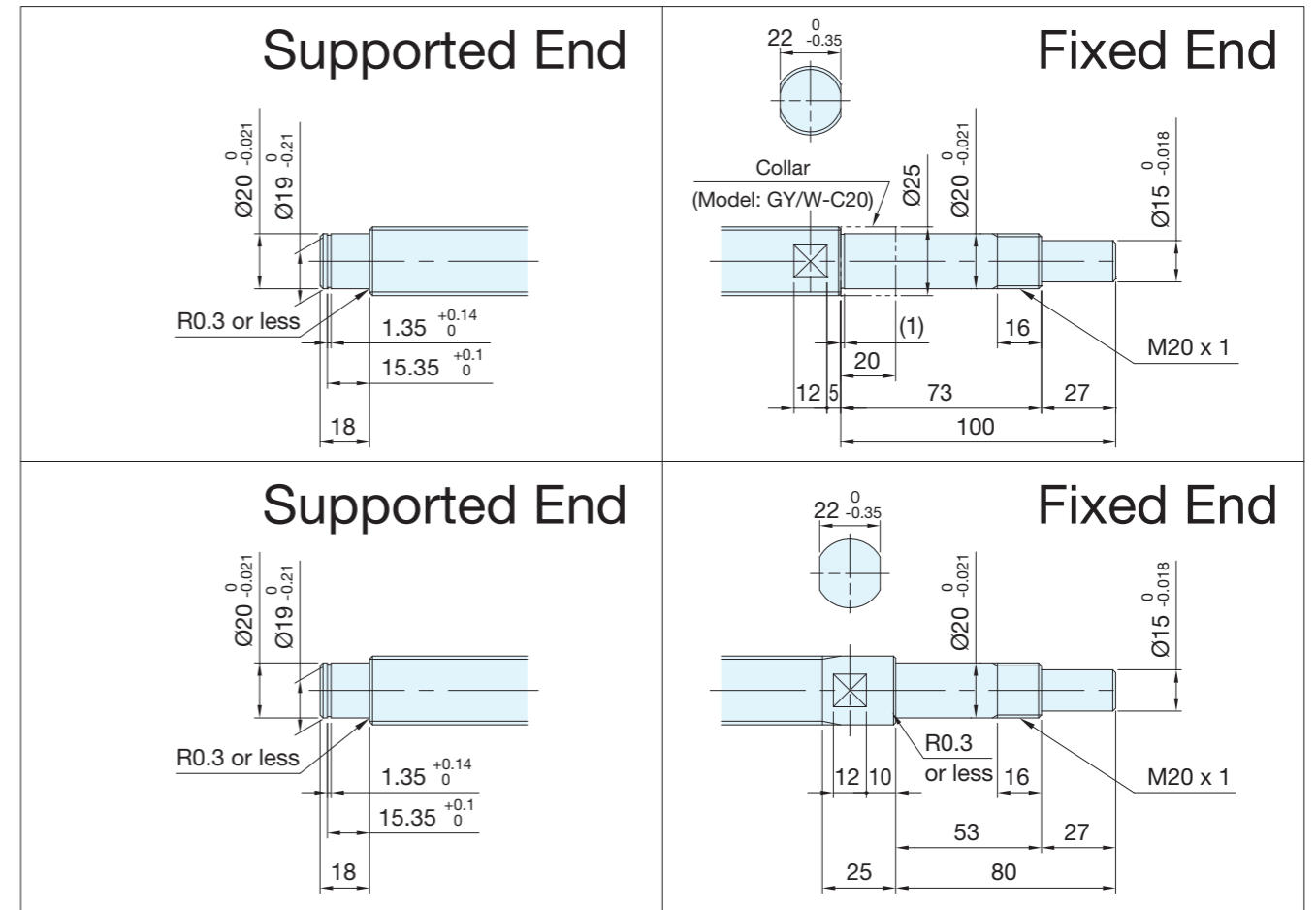

Applicable Support Units

Applicable supported end support units	Applicable fixed end support units
BUK-20S (square) Refer to page 22	BUK-20F (square) Refer to page 22
BUM-20S (round) Refer to page 23	BUM-20F (round) Refer to page 23

Optional Specifications

Anti-rust black oxide film treatment (film thickness 1-2 μ m) is available.

Compatible Support Units

Square Support Units/BUK Series

Fixed End Support Units

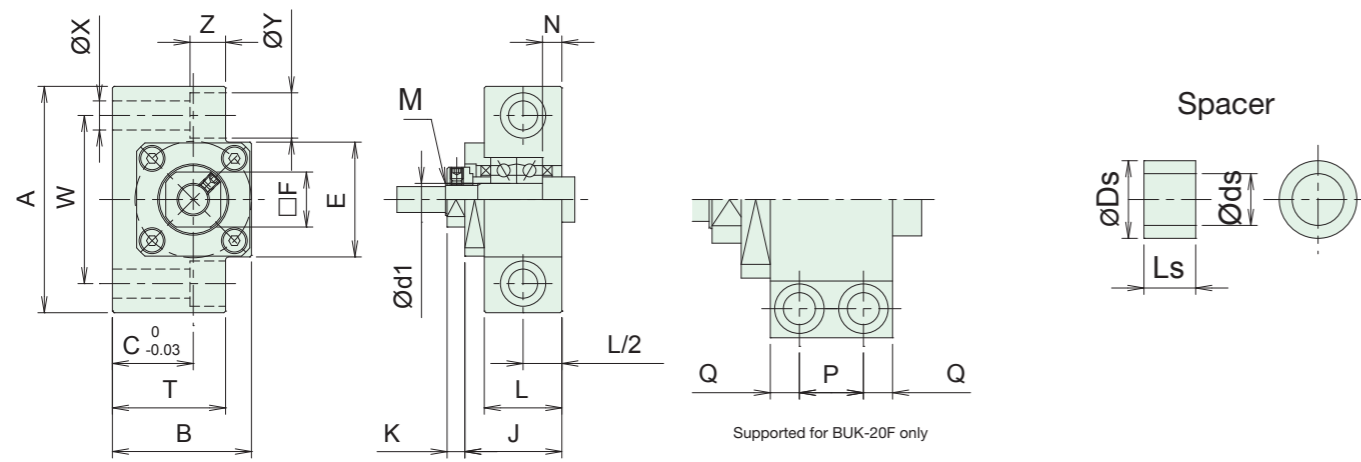

(unit: mm)

Model Number	Ød1	A	B	C	T	E	□F	J	K	L	N	P	Q	W	X	Y	Z	M	Øds	ØDs	Ls	Weight (kg)
BUK-10F	10	70	43	25	35	35.5	17	30	5.5	24	6	-	-	52	9	14	11	M10 x 1	10	14	5.5	0.49
BUK-12F	12	70	43	25	35	35.5	19	30	5.5	24	6	-	-	52	9	14	11	M12 x 1	12	15	5.5	0.50
BUK-15F	15	80	50	30	40	41	22	31	12	25	5	-	-	60	11	17	15	M15 x 1	15	20	10	0.65
BUK-20F	20	95	58	30	45	56	30	52	10	42	10	22	10	75	11	17	15	M20 x 1	20	25	11	1.48

(Note 1) The weight above does not include packaging.

Supported End Support Units

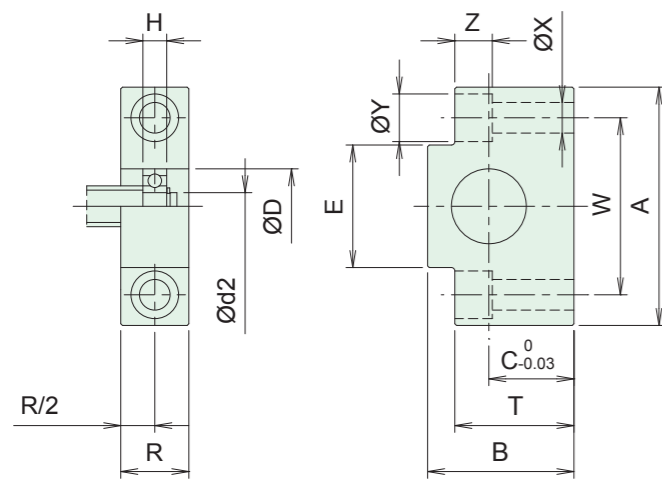

For Fixed/supported Shaft End Configuration

Model Number	Model Number
BUK-10F	BUK- 8S
BUK-12F	BUK-10S
BUK-15F	BUK-15S
BUK-20F	BUK-20S

(unit: mm)

Model Number	Ød2	ØD	H	R	A	B	C	T	E	W	X	Y	Z	Shaft Stop Ring	Weight (kg)
BUK-8S	8	22	7	20	70	43	25	35	35.5	52	9	14	11	Nominal 8	0.37
BUK-10S	10	26	8	20	70	43	25	35	35.5	52	9	14	11	Nominal 10	0.36
BUK-15S	15	32	9	20	80	50	30	40	41	60	11	17	15	Nominal 15	0.46
BUK-20S	20	47	14	26	95	58	30	45	56	75	11	17	15	Nominal 20	0.76

(Note 1) The weight above does not include packaging.

Compatible Support Units

Round Support Units/BUM Series

Fixed End Support Units

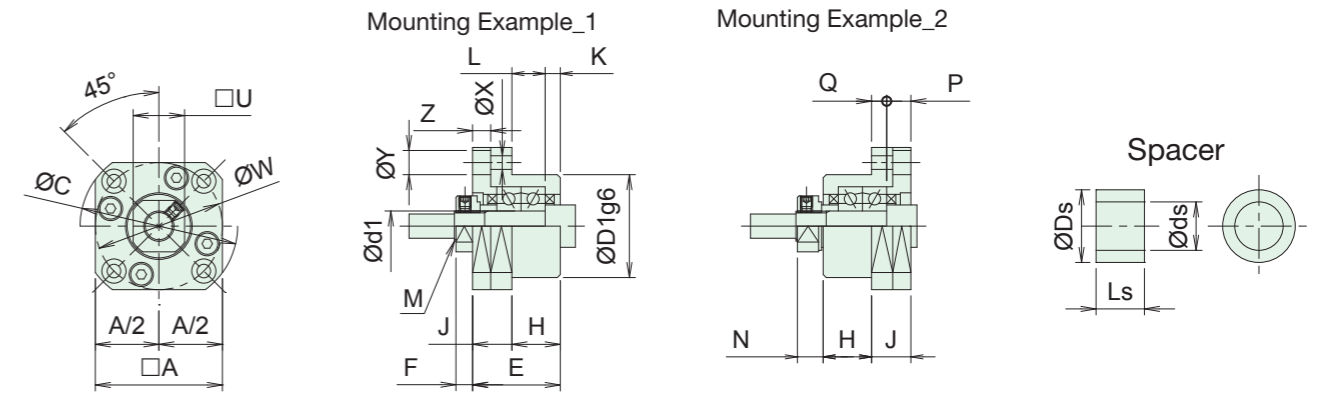

(unit: mm)

Model Number	Ød1	□A	ØC	ØD1	E	F	H	J	K	L	N	P	Q	□U	ØW	X	Y	Z	M	Øds	ØDs	Ls	Weight (kg)
BUM-10F	10	42	52	34	29	5.5	16	13	5	11	8.5	8	5	17	42	4.5	8	6	M10 x 1	10	14	5.5	0.24
BUM-12F	12	44	54	36	29	5.5	16	13	5	11	8.5	8	5	19	44	4.5	8	6	M12 x 1	12	15	5.5	0.26
BUM-15F	15	52	63	40	32	12	17	15	6	11	14	8	7	22	50	5.5	9.5	6	M15 x 1	15	20	10	0.40
BUM-20F	20	68	85	57	52	10	30	22	10	20	14	14	8	30	70	6.6	11	10	M20 x 1	20	25	11	1.09

(Note 1) The weight above does not include packaging.

Supported End Support Units

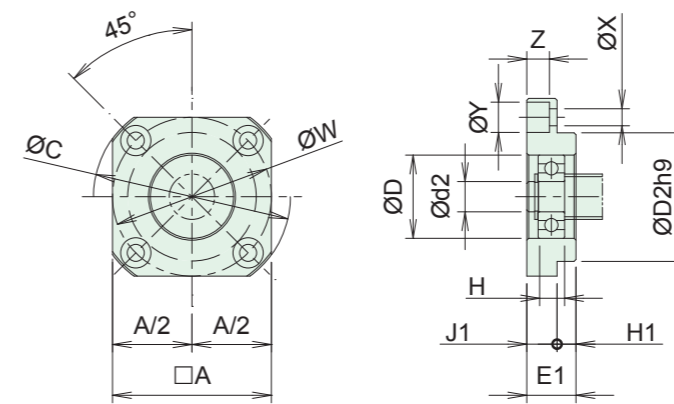

For Fixed/supported Shaft End Configuration

Model Number	Model Number
BUM-10F	BUM- 8S
BUM-12F	BUM-10S
BUM-15F	BUM-15S
BUM-20F	BUM-20S

(unit: mm)

Model Number	Ød2	ØD	H	□A	ØC	Ød2	E1	J1	H1	ØW	X	Y	Z	Shaft Stop Ring	Weight (kg)
BUM-8S	8	22	7	42	52	34	13	8	5	42	4.5	8	6	Nominal 8	0.11
BUM-10S	10	26	8	44	54	36	15	7	8	44	4.5	8	6	Nominal 10	0.12
BUM-15S	15	32	9	52	63	40	17	9	8	50	5.5	9.5	6	Nominal 15	0.17
BUM-20S	20	47	14	68	85	57	20	11	9	70	6.6	11	10	Nominal 20	0.38

(Note 1) The weight above does not include packaging.

Low Particle Generating Grease

KURODA S-Grease

Meeting particle prevention needs for linear motion products used in semiconductor manufacturing machines, LCD-related equipment, medical-related devices and more. Superior lubrication characteristics provide excellent torque performance.

Major Characteristics

Appearance	Yellow-white
Thickener	Urea
Base Oil	Mineral oil
Consistency	280 (No. 2)
Operating Temperature Range	-20 to +150°C

Low Particle Generation

- Delivers superior low particle generation performance compared with standard lithium-based grease.

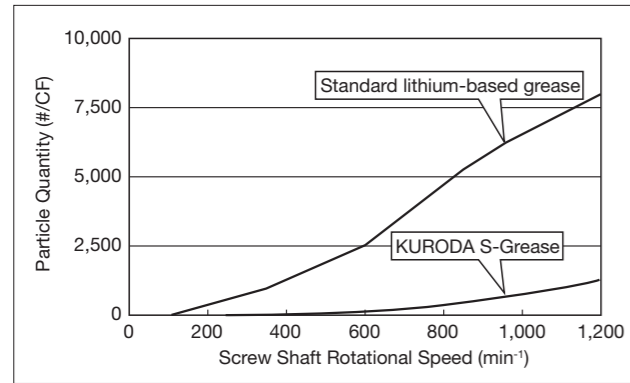

Test conditions	
Screw Shaft Diameter	φ20 mm
Lead	20 mm
Axial Load	800 N

Lubrication Characteristics:

Comparison of Torque Change Before and After Operation

Test conditions	
Screw Shaft Diameter	φ20 mm
Lead	20 mm
Preload Torque	30 N·cm

- There is hardly any change in torque even after 1,000 km of operation.

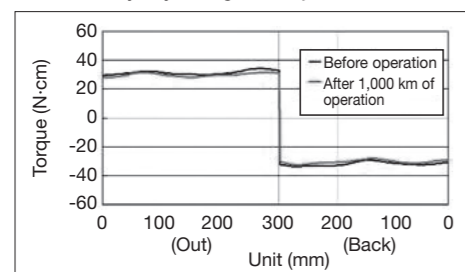

Torque Characteristics:

Comparison with Competitors' Grease with Low Particle Generation

Test conditions	
Screw Shaft Diameter	φ16 mm
Lead	2 mm
Operating Stroke	0.5 mm

- Delivers stable torque characteristics even during oscillating operation.

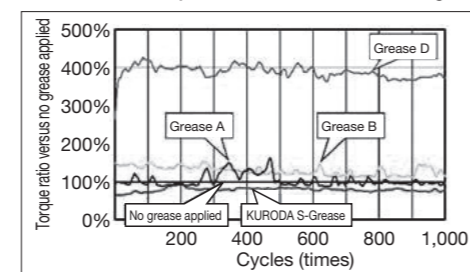

Anti-rust Performance

- Delivers top anti-rust characteristics during bearing anti-rust testing (48 hours at 52°C).
- * "Top" here indicates a complete absence of rust under the test conditions described above.



Proper usage for safety

Be sure to read the following instructions before use.
For general instructions, refer to the text of this catalog.

The following safety precautions recommend the correct usage of our products to prevent injury or damage. These precautions are classified into 3 categories: "DANGER", "WARNING", and "CAUTION" according to the degree of possible injury or damage and the degree of impendence of such injury or damage. Be sure to follow all these precautions, as they contain important matters regarding safety.

DANGER	WARNING	CAUTION
Indicates an impending hazardous situation that may arise due to improper handling or operation and could result in a serious injury or death.	Indicates a potentially hazardous situation that may arise due to improper handling or operation and could result in a serious injury or death.	Indicates a potentially hazardous situation that may arise due to improper handling or operation and could result in an injury or property damage only.

Be sure to obey the Industrial Safety Health Act and other safety rules and regulations in addition to these precautions. There are some situations that may lead to serious results according to circumstances, even if covered under "CAUTION". Be sure to follow these precautions, as they contain important matters.

WARNING

- Select a ball screw properly.**
As operating conditions for products mentioned in this catalog are diverse, the applicability of the ball screw to the intended system should be determined by the overall system designer or the person who determined the system specifications after conducting analysis and testing as necessary.
The person who determined the applicability of the system shall be responsible for ensuring the intended system's performance and safety. When configuring the system, the system designer should thoroughly examine all system specifications with reference to the latest product catalog and data, and also take into consideration the possibility of equipment-related issues.
- The ball screw should be handled by persons who have sufficient knowledge and experience.**
 - Thoroughly read this catalog and operation manual before use.
 - Never disassemble the ball screw. Dust may enter, degrading the accuracy of the ball screw and leading to an accident. When the ball screw must be disassembled, return it afterward to KURODA for repair and reassembling. (Fees will be incurred.)
 - When mounting the ball screw to a machine and dismantling it from the machine, check that a means of fall prevention has been put in place and that the machine moving parts have been fixed beforehand.
- The products listed here are primarily for industrial use. When using the ball screw in the following conditions or environments, take the proper safety measures and consult KURODA beforehand.**
 - Conditions and environments other than specified, and outdoor use.
 - Application to nuclear power equipment, railroads, aircraft, vehicles, medical equipment, equipment contacting food and drink, and the like.
 - Applications which require extreme safety and will also greatly affect persons and property.
- During operation, make sure to keep your hands away from threaded sections and ends of ball screw shafts, which are rotating parts, to prevent your hands from being caught.**
- Pay adequate attention not to allow the products to be used for military purposes, including for arms and weapons.**



Ball screw/General instructions (1)

Be sure to read the following instructions before use.
Also refer to "Proper usage for safety".

Cautions for design

WARNING

● Rotational speed

Referring to the section describing allowable rotational speed in this catalog, use the ball screw at or lower than the listed allowable rotational speed. Using the product at or above the specified DN value could cause damage of its recirculation components and result in inoperable conditions. When using a vertical shaft, the damage may lead to dangerous accidents such as falling balls or parts.

CAUTION

● Dust preventive cover

If it is likely that dust or other contaminant may enter the ball screw, be sure to attach a dust preventive cover, such as bellows or lead screw cover (steel bellows). Attaching a wiper at both ends of the nut will be more effective for dust prevention.

Dust or contaminant caught in the ball screw could cause various defects including malfunction, abnormal noise, excessive vibration, accelerated wear-out, and premature chipping.

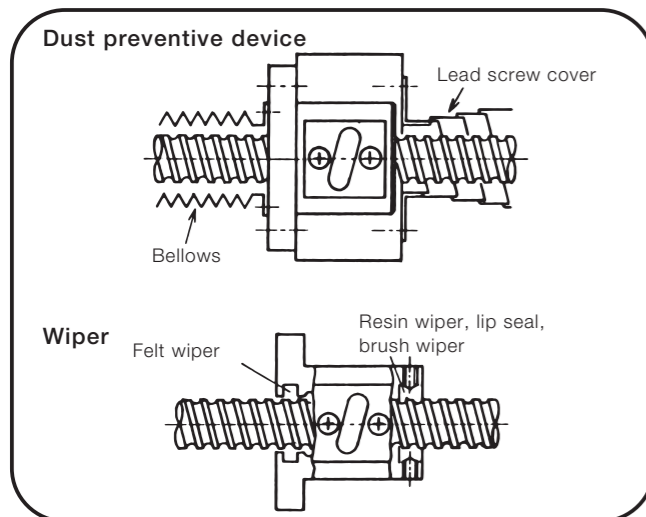

● Imbalanced load

In your system design, ensure that a radial or moment load is not directly applied to the ball screw. Otherwise, it may result in shorter product service life due to concentrated load to a certain portion of balls in the screw.

● Mounting of the ball screw

When mounting the ball screw to a machine, the system design should allow its screw shaft to be mounted without taking off the nut.

Removing and attaching the nut may cause some balls to drop outside of their recirculation path, which may result in damage of recirculation components. If removal of the nut is inevitable, consult KURODA beforehand.

Cautions for mounting and use

WARNING

● Do not overrun the product.

If the ball screw nut is overrun and receives an impact at the stroke end, the resulting thread groove impressions could cause malfunction. If the thread groove end has a part with an incomplete thread, this could damage ball recirculation components, which may result in inoperable conditions. If a ball screw nut has been allowed to overrun, please contact KURODA. Return the product to KURODA for repair. (Fees will be incurred.)

● Pay adequate attention to the accuracy grade.

Moment load caused by misalignment of the ball screw, bearing, guide, nut, or housing and improper angularity may result in malfunction, abnormal noise, excessive vibration, shorter product service life as well as breakage of screw shafts due to rotating bending fatigue. Be careful of these malfunctions, which may lead to a serious accident.

● Be careful to prevent parts from falling due to their own weight.

Since the ball screw has a low friction factor, its shaft or nut could potentially fall off due to its own weight. Be careful not to snag your hand or fingers in components.

● Do not touch the ball screw with bare hands.

The screw shaft and nut corners may have sharp edges for structural reasons, and there may be a risk of injuries such as cuts.

In order to prevent injuries, take adequate care when handling products and wear protective equipment such as gloves during work.

CAUTION

● Do not remove the nut.

If the ball has fallen from the nut or the shaft and the nut have been separated, do not attempt to reassemble them yourself. Return the product to KURODA for repair. (Fees will be incurred.)

● Be careful of any dust or contaminants.

While assembling the machine, put on a cover to prevent the screw shaft from attracting any dust or contaminants. These contaminants could cause malfunction of the machine.

● When a component such as bearing, gear, or pulley is attached to the screw shaft, handle them with care so that there is no damage from impact. This impact could cause the screw shaft to bend.

If an impact is accidentally applied to the shaft, check whether it is bent first by checking the coupling of the screw shaft with a dial gauge, before assembling the additional components.

● Use the product within the operating temperature limit.

Ball screws are designed to have a normal operating temperature limit of 50°C or below. Using them in an environment exceeding the operating temperature limit may result in damaged lubrication or sealing components.

If you need to use the screw in a special environment, consult with KURODA beforehand.



Ball screw/General instructions (2)

Be sure to read the following instructions before use.
Also refer to "Proper usage for safety".

Lubricants

CAUTION

● Type of lubricant

Unless specified, lithium-based grease is contained in the nut as lubricant. Since anti-rust oil applied to the screw shaft also serves as lubricant, the ball screw can be used without additional application.

Storage

CAUTION

● Storage method

Store the ball screws indoors with as little temperature difference as possible, avoiding high and low temperatures and high humidity.

Store in a horizontal state in the packaging originally sent by KURODA. In order to prevent unnecessary contamination due to dust or rusting of the ball screws, do not open the outer packaging or any of the internal packaging unless necessary.

Checkup and caution

CAUTION

● Checking the lubricant status and application of grease

For the sake of usability and dust/contaminant prevention, lubricant for ball screws is, in general, contained only in the nut. When specified or required for overseas export, lubricant may be applied to the screw shaft.

Depending on the screw size and screw shaft length, the amount of grease in the nut may not be sufficient. After running the nut back and forth the length of the shaft, check to see if the rolling side of the thread groove has enough grease on it. If the amount is not enough, apply additional grease to the screw shaft.

● Checkup and reapplication of lubricant

Check the lubricant 2 to 3 months after the ball screw is used for the first time. If it is extremely dirty, it is recommended that you wipe off old grease and apply new grease. After that, check and supply the lubricant once every year as a general rule. However, as the service life of lubricants varies according to operating conditions and environment, adjust the intervals properly.

When reapplying additional lubricant, use the same brand of lubricant as was initially included.

For a ball screw model provided with a nut which does not have an oil hole, supply a sufficient amount of grease directly to the screw shaft and thread groove, carefully applying it over the components until the grease goes into the nut.

For a model provided with a nut having an oil hole, supply the necessary amount of grease from the oil hole or a feeder (grease fitting, etc.).

After applying additional grease, operate for a full stroke to ensure the proper coverage of the grease on all components. Wipe off excess grease attached on the end of the screw shaft. For more details on the size of the oil hole, refer to the dimensions for each size.

KURODA PRECISION INDUSTRIES LTD.

<https://www.kuroda-precision.com/>

HEAD OFFICE 580-16, Horikawa-cho, Saiwai-ku, Kawasaki, Kanagawa 212-8560, Japan
Tel: +81-(0)44-555-3805 Fax: +81-(0)44-555-1479
Email: ovs_dpt@kuroda-precision.co.jp

KURODA JENA TEC INC.
3939 Royal Drive Suite 143 Kennesaw, GA 30144 U.S.A.
Tel: 1-770-926-6705 Fax: 1-770-926-6724
Email: sales@kurodajenatec.com

JENAER GEWINDETECHNIK GmbH
Victor-Goerttler-Str.3, 07745 Jena, Germany
Tel: +49-(0)3641-68980 Fax: +49-(0)3641-689860
Email: info@jena-tec.de

KURODA PRECISION INDUSTRIES KOREA LTD.
202F 110, Ls-Ro 144 Beon-Gil, Dongan-gu,
Anyang-si, Gyeonggi-do, 14083, Korea
Tel: +82-31-451-4920 Fax: +82-31-451-4921
Email: mail@kuroda.kr

KURODA PRECISION INDUSTRIES PINGHU CO.,LTD Headquarters
383, Xingye Road, Pinghu Economic Development Zone, Pinghu Zhejiang,
P.R. China, P.C: 314200
Tel: +86-573-85010786 Fax: +86-573-85014123
Email: kpp@kuroda-pinghu.com

KURODA PRECISION INDUSTRIES PINGHU CO.,LTD Shenzhen Office
202-45 Room Noble Plaza 269 Qianjin Road, Baoan District, Shenz hen
P.R. China, P.C:518000
Tel: +86-755-23289740 Fax: +86-755-23289740

Internet Support Service

<https://www.kuroda-precision.com/>

KURODA provides product information and CAD data online which can be downloaded.

In addition, please note that you need to register on the PART community to use 3D-CAD data.



* The contents herein are information as of the end of Sep. 2024.
The appearance or specifications of products may be changed without prior notice in order to respond to technical progress and improvements.